

TB 9-6625-1098-35

CHANGE 4

DEPARTMENT OF THE ARMY TECHNICAL BULLETIN

CALIBRATION PROCEDURE FOR DISTORTION ANALYZERS AN/URM-184A, AND HEWLETT-PACKARD, MODELS 331A, 332A, 333A (WITH OPTIONS) AND 334A (WITH OPTIONS)

Headquarters, Department of the Army, Washington, DC
10 November 2005

Distribution Statement A: Approved for public release; distribution is unlimited.

TB 9-6625-1098-35, 5 April 2004, is changed as follows:

1. Remove old pages and insert new pages as indicated below. New or changed material is indicated by a vertical bar in the margin of the page.

Remove Pages

3 and 4
15 and 16

Insert Pages

3 and 4
15 and 16

2. File this change sheet in front of the publication for reference purposes.

By Order of the Secretary of the Army:

Official



SANDRA R. RILEY

*Administrative Assistant to the
Secretary of the Army*

0525804

PETER J. SCHOOMAKER
*General, United States Army
Chief of Staff*

Distribution:

To be distributed in accordance with IDN 342118, requirements for calibration procedure TB 9-6625-1098-35.

TB 9-6625-1098-35

CHANGE 3

DEPARTMENT OF THE ARMY TECHNICAL BULLETIN

CALIBRATION PROCEDURE FOR DISTORTION ANALYZERS AN/URM-184A, AND HEWLETT-PACKARD, MODELS 331A, 332A, 333A (WITH OPTIONS) AND 334A (WITH OPTIONS)

Headquarters, Department of the Army, Washington, DC
24 August 2005

Distribution Statement A: Approved for public release; distribution is unlimited.

TB 9-6625-1098-35, 5 April 2004, is changed as follows:

1. Remove old pages and insert new pages as indicated below. New or changed material is indicated by a vertical bar in the margin of the page.

Remove Pages
5 and 6

Insert Pages
5 and 6

2. File this change sheet in front of the publication for reference purposes.

By Order of the Secretary of the Army:

Official



SANDRA R. RILEY

*Administrative Assistant to the
Secretary of the Army*

0517801

PETER J. SCHOOMAKER
*General, United States Army
Chief of Staff*

Distribution:

To be distributed in accordance with IDN 342118, requirements for calibration procedure TB 9-6625-1098-35.

TB 9-6625-1098-35

CHANGE 2

DEPARTMENT OF THE ARMY TECHNICAL BULLETIN

CALIBRATION PROCEDURE FOR DISTORTION ANALYZERS AN/URM-184A, AND HEWLETT-PACKARD, MODELS 331A, 332A, 333A (WITH OPTIONS) AND 334A (WITH OPTIONS)

Headquarters, Department of the Army, Washington, DC
15 March 2005

Distribution Statement A: Approved for public release; distribution is unlimited.

TB 9-6625-1098-35, 5 April 2004, is changed as follows:

1. Remove old pages and insert new pages as indicated below. New or changed material is indicated by a vertical bar in the margin of the page.

Remove Pages

11 and 12
13 and 14

Insert Pages

11 and 12
13 and 14

2. File this change sheet in front of the publication for reference purposes.

By Order of the Secretary of the Army:

Official



SANDRA R. RILEY

*Administrative Assistant to the
Secretary of the Army*

0501902

PETER J. SCHOOMAKER
*General, United States Army
Chief of Staff*

Distribution:

To be distributed in accordance with IDN 342118, requirements for calibration procedure TB 9-6625-1098-35.

TB 9-6625-1098-35

CHANGE 1

DEPARTMENT OF THE ARMY TECHNICAL BULLETIN

CALIBRATION PROCEDURE FOR DISTORTION ANALYZERS AN/URM-184A, AND HEWLETT-PACKARD, MODELS 331A, 332A, 333A (WITH OPTIONS) AND 334A (WITH OPTIONS)

Headquarters, Department of the Army, Washington, DC
4 November 2004

Distribution Statement A: Approved for public release; distribution is unlimited.

TB 9-6625-1098-35, 5 April 2004, is changed as follows:

1. Remove old pages and insert new pages as indicated below. New or changed material is indicated by a vertical bar in the margin of the page.

Remove Pages

15 and 16
17 and 18

Insert Pages

15 and 16
17 and 18

2. File this change sheet in front of the publication for reference purposes.

By Order of the Secretary of the Army:

Official:



SANDRA R. RILEY
Administrative Assistant to the
Secretary of the Army
0425205

PETER J. SCHOOMAKER
General, United States Army
Chief of Staff

Distribution:

To be distributed in accordance with IDN 342118, requirements for calibration procedure TB 9-6625-1098-35.

***TB 9-6625-1098-35**

DEPARTMENT OF THE ARMY TECHNICAL BULLETIN

CALIBRATION PROCEDURE FOR DISTORTION ANALYZERS AN/URM-184A, AND HEWLETT-PACKARD, MODELS 331A, 332A, 333A (WITH OPTIONS) AND 334A (WITH OPTIONS)

Headquarters, Department of the Army, Washington, DC
5 April 2004

Distribution Statement A: Approved for public release; distribution is unlimited.

REPORTING OF ERRORS AND RECOMMENDING IMPROVEMENTS

You can improve this manual. If you find any mistakes or if you know of a way to improve these procedures, please let us know. Mail your letter or DA Form 2028 (Recommended Changes to Publications and Blank Forms) directly to: Commander, US Army Aviation and Missile Command, AMSAM-MMC-MA-NP, Redstone Arsenal, AL 35898-5000. A reply will be furnished to you. You may also provide DA Form 2028 information to AMCOM via e-mail, fax, or the World Wide Web. Our fax number is DSN 788-6546 or Commercial 256-842-6546. Our e-mail address is 2028@redstone.army.mil. Instructions for sending an electronic 2028 may be found at the back of this manual. For the World Wide Web, use <https://amcom2028.redstone.army.mil>.

SECTION		Paragraph	Page
	I. IDENTIFICATION AND DESCRIPTION		
	Test instrument identification	1	2
	Forms, records, and reports	2	3
	Calibration description	3	3
	II. EQUIPMENT REQUIREMENTS		
	Equipment required	4	4
	Accessories required	5	4
	III. CALIBRATION PROCESS		
	Preliminary instructions	6	5
	Equipment setup	7	5
	Voltmeter accuracy	8	6
	Voltmeter frequency response.....	9	7

*This bulletin supersedes TB 9-6625-1098-35, dated 21 June 1988, including all changes.

	Paragraph	Page
High pass filter (Hewlett-Packard Models 333A and 334A).....	10	9
Low pass filter (Hewlett-Packard Model 334A option 002).....	11	10
Voltmeter residual noise	12	10
Set level sensitivity.....	13	10
Frequency dial accuracy.....	14	11
Second harmonic rejection	15	13
Automatic null (Hewlett-Packard Models 333A and 334A).....	16	14
Fundamental frequency rejection.....	17	15
Fundamental frequency rejection (alternate method).....	18	17
Power supply	19	18
Final procedure	20	19

**SECTION I
IDENTIFICATION AND DESCRIPTION**

1. Test Instrument Identification. This bulletin provides instructions for the calibration of Distortion Analyzers AN/URM-184A and Hewlett-Packard, Models 331A, 332A, 333A (With Options) and 334A (With Options). The manufacturers' manuals and TM 11-6625-1576-15 were used as the prime data sources in compiling these instructions. The equipment being calibrated will be referred to as the TI (test instrument) throughout this bulletin.

a. Model Variations

(1) The following options may apply to Hewlett-Packard Models 333A and 334A instruments:

- (a) Opt 01 provides an indicating meter with VU ballistic characteristics.
- (b) Opt 002 and H05 provides a low-pass filter in place of high-pass filter in Hewlett-Packard Model 334A.

(2) For simplification, test applications only refer to Hewlett-Packard model numbers throughout text.

b. Time and Technique. The time required for this calibration is approximately 4 hours, using the dc and low frequency technique.

2. Forms, Records, and Reports

a. Forms, records, and reports required for calibration personnel at all levels are prescribed by TB 750-25.

b. Adjustments to be reported are designated (R) at the end of the sentence in which they appear. When adjustments are in tables, the (R) follows the designated adjustment. Report only those adjustments made and designated with (R).

3. Calibration Description. TI parameters and performance specifications which pertain to this calibration are listed in table 1.

Table 1. Calibration Description

Test instrument parameters	Performance specifications
Voltmeter range and accuracy 300 μ V range 1 mV to 30 V range 100 to 300 V range	$\pm 2\%$, 30 Hz to 300 kHz $\pm 5\%$, 20 Hz to 500 kHz $\pm 2\%$, 10 Hz to 1 MHz $\pm 5\%$, 5 Hz to 3 MHz $\pm 2\%$, 10 Hz to 300 kHz $\pm 5\%$, 5 Hz to 500 kHz
High pass filter (Hewlett-Packard Models 333A and 334A)	3 dB down at 400 Hz; 60 Hz rejection >40 dB
Low pass filter (Hewlett-Packard Model 334A option 002)	3 dB down at 30 kHz; -23.6 dB at 60 kHz
Residual noise	<25 μ V rms with input shielded and terminated with 600 Ω
Set level sensitivity	0.3 rms for 100% set level (up to 300 V may be attenuated to set level reference)
Frequency calibration accuracy	$\pm 5\%$, 5 Hz to 300 kHz $\pm 10\%$, 300 to 600 kHz
Second harmonic range and accuracy	5 to 20 Hz, >+1 dB 20 Hz to 20 kHz $\geq \pm 0.6$ dB 20 to 100 kHz ≥ -1 dB 100 to 300 kHz ≥ -2 dB 300 to 600 kHz ≥ -3 dB
Residual distortion ¹	>-70 dB, 5 Hz to 200 kHz >-64 dB, 200 to 600 kHz
Automatic null (Hewlett-Packard Models 333A and 334A)	0 to +3 dB from manual null (5 to 100 Hz) 0 to +1.5 dB from manual null (100 Hz to 600 kHz)
Fundamental frequency rejection	>80 dB

¹Implicitly calibrated during voltmeter residual noise calibration.

**SECTION II
EQUIPMENT REQUIREMENTS**

4. Equipment Required. Table 2 identifies the specific equipment to be used in this calibration procedure. This equipment is issued with Secondary Transfer Calibration Standards Set AN/GSM-287 or AN/GSM-705. Alternate items may be used by the calibrating activity. The items selected must be verified to perform satisfactorily prior to use and must bear evidence of current calibration. The equipment must meet or exceed the minimum use specifications listed in table 2. The accuracies listed in table 2 provide a four-to-one ratio between the standard and TI. Where the four-to-one ratio cannot be met, the actual accuracy of the equipment selected is shown in parenthesis.

5. Accessories Required. The accessories required for this calibration are common usage accessories, issued as indicated in paragraph 4 above, and are not listed in this calibration procedure. The following peculiar accessory is also required for this calibration: Voltage Divider, 600 Ω, double banana plug to triple banana jack, Hewlett-Packard, model 11047A (7911560).

Table 2. Minimum Specifications of Equipment Required

Common name	Minimum use specifications	Manufacturer and model (part number)
CALIBRATOR	Range: 249 μV to 306 V rms Accuracy: ± 0.5%	Fluke, Model 5720A (5700A/EP) (p/o MIS-35947); w/power amplifier, Fluke 5725A (5725A)
ELECTRONIC FILTER	Range: 500 Hz to 600 kHz Roll-off: 24 dB/octave bandpass 48 dB/octave low pass	Krohn-Hite Model 3940 (3940)
MULTIMETER	Range: 0 to 30 V dc Accuracy: ± 0.5%	Fluke, Model 8840A/AF-05/09 (AN/GSM-64D)
RATIO TRANSFORMER	Ratio: 0.001 Accuracy: ± 0.1%	ESI, Model DT72A (7915908)
SPECTRUM ANALYZER	Range: 500 Hz to 100 kHz Accuracy: <80 dB	Hewlett Packard, Model 3585A
TRUE RMS VOLTMETER	Range: 1 mV to 1 V rms Accuracy: ± 1%	Fluke, Model 8922A/AA (8922A/AA)

SECTION III CALIBRATION PROCESS

6. Preliminary Instructions

a. The instructions outlined in paragraphs 6 and 7 are preparatory to the calibration process. Personnel should become familiar with the entire bulletin before beginning the calibration.

b. Items of equipment used in this procedure are referenced within the text by common name as listed in table 2.

c. Unless otherwise specified, verify the result of each test and, whenever the test requirement is not met, take corrective action before continuing with the calibration. Adjustments required to calibrate the TI are included in this procedure. Additional maintenance information is contained in the manufacturers' manuals and TM 11-6625-1576-15, for this TI.

d. When indications specified in paragraphs 8 through 18 are not within tolerance, perform the power supply check prior to making adjustments. After adjustments are made, repeat paragraphs 8 through 18. Do not perform power supply check if all other parameters are within tolerance.

e. Unless otherwise specified, all controls and control settings refer to the TI.

7. Equipment Setup

WARNING

HIGH VOLTAGE is used or exposed during the performance of this calibration. DEATH ON CONTACT may result if personnel fail to observe safety precautions. REDUCE OUTPUT(S) to minimum after each step within the performance check where applicable.

a. Remove protective cover from TI as necessary for access to adjustments and test points. Reinstall cover after completing check or adjustment.

b. Connect TI to a 115 V ac source.

c. Position TI switches as listed in (1) through (4) below:

(1) **METER RANGE** to **300 VOLTS**

(2) **HIGH PASS FILTER** to **OUT**.

(3) **NORM/RF DET** to **NORM** (model 334A only).

(4) Power to **ON** and allow at least 20 minutes for TI to warm-up and stabilize.

d. Set power switch to **OFF** and perform mechanical zero on TI meter, using mechanical zero adjustment screw located directly below meter.

e. Set power switch to **ON**.

8. Voltmeter Accuracy

a. Performance Check

- (1) Remove shorting bar connecting TI circuit ground to chassis ground.
- (2) Set **FUNCTION** switch to **VOLTMETER**.
- (3) Connect calibrator **OUTPUT** to ratio standard **INPUT** and connect ratio transformer **OUTPUT** to **TI INPUT**.
- (4) Set **METER RANGE** switch to **.0003 VOLTS** and adjust ratio transformer for a 0.01 ratio.
- (5) Adjust calibrator frequency for 1 kHz and 0.0003 V indication on TI meter. Calibrator will indicate between 29.4 and 30.6 mV.
- (6) Set **METER RANGE** switch to **.001 VOLTS**
- (7) Adjust calibrator frequency for 400 Hz and 0.001 V indication on TI meter. If calibrator does not indicate between 0.098 and 0.102 V, perform **b** below.
- (8) Place calibrator in **STBY** and remove calibrator connection from ratio standard and connect directly to **TI INPUT**.
- (9) Repeat technique of (6) and (7) above for **METER RANGE** switch settings and meter indications listed in table 3 below. Calibrator will indicate within limits specified.

Table 3. Voltmeter Accuracy

Test instrument		Calibrator indications	
METER RANGE switch settings (VOLTS)	Meter indications (V)	(V)	
		Min	Max
.003	0.003	0.00294	0.00306
.01	0.01	0.0098	0.0102
.03	0.03	0.0294	0.0306
.1	0.1	0.098	0.102
.3	0.3	0.294	0.306
1	0.2	0.18	0.22
1	0.4	0.38	0.42
1	0.6	0.58	0.62
1	0.8	0.78	0.82
1	1	0.98	1.02
3	3	2.94	3.06
10	10	9.8	10.2
30	30	29.4	30.6
100	100	98.0	102.0
300	300	294.0	306.0

b. Adjustments

- (1) Adjust calibrator for a 0.1 V, 400 Hz output.

6 CHANGE 3

(2) Adjust A2R34 (fig. 1) for 0.001 V indication on TI voltmeter (R).

9. Voltmeter Frequency Response

a. Performance Check

(1) Connect calibrator **WIDEBAND** output to **TI INPUT** using cable and 50 Ω feedthrough termination provided with calibrator for wideband operation.

(2) Set **METER RANGE** switch to **.001 VOLTS**.

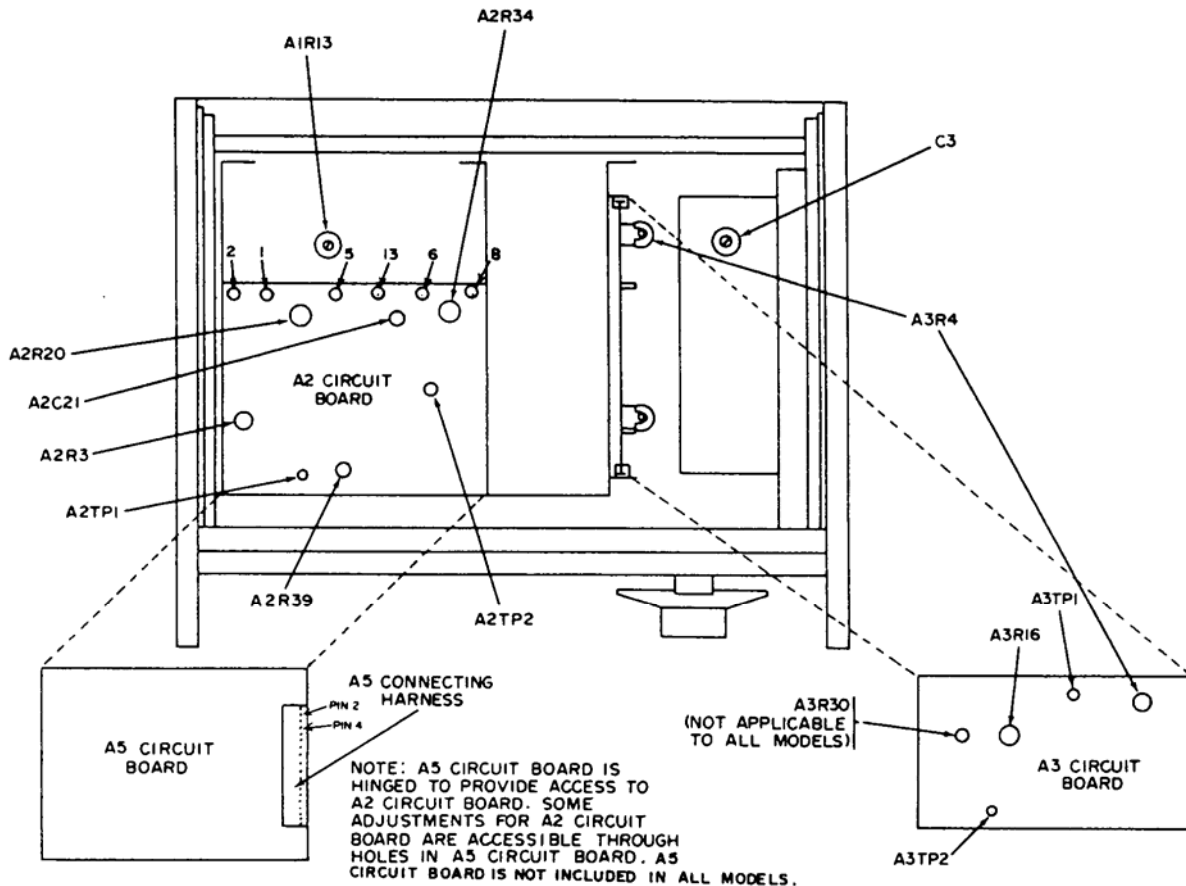

Figure 1. Distortion analyzer - top view.

(3) Select calibrator **WBAND** operation. Adjust calibrator frequency to 1 kHz and amplitude for a 0.001 V indication on TI meter.

(4) Set the reference level on calibrator by pressing the **NEW REF** key.

(5) Vary calibrator frequency from 10 Hz to 1 MHz while maintaining TI meter indication of 0.001 V. If calibrator error display does not indicate within ± 2 percent of reference in (4) above, perform **b** below.

TB 9-6625-1098-35

(6) Repeat technique of (5) above while varying calibrator wideband frequency from 1 to 3 MHz. If calibrator error display does not indicate within ± 5 percent of reference in (4) above, perform **b** below.

(7) Set **METER RANGE** switch to **.003 VOLTS**.

(8) Adjust calibrator frequency to 1 kHz and amplitude for a 0.003 V indication on TI meter. Set the reference level on calibrator by pressing the **NEW REF** key.

(9) Vary calibrator frequency from 10 Hz to 1 MHz while maintaining a 0.003 V indication on TI meter. If calibrator error display does not indicate within ± 2 percent of reference in (8) above, perform **b** below.

(10) Repeat technique of (8) above varying calibrator frequency from 1 to 3 MHz. If calibrator error display does not indicate within ± 5 percent of reference in (8) above, perform **b** below.

(11) Repeat technique of (7) through (10) above for **.01**, **.3**, and **3 VOLTS** ranges, using TI meter indications corresponding to **METER RANGE** switch setting. If calibrator error display does not indicate within limits specified in (9) and (10) above, perform **b** below.

b. Adjustments

(1) Set **METER RANGE** switch to **.01 VOLTS**.

(2) Adjust calibrator frequency to 1 kHz and amplitude for a 0.01 V indication on TI meter. Set the reference level on calibrator by pressing the **NEW REF** key.

(3) Adjust calibrator frequency to 2 MHz and output amplitude for 0.0% error display reading.

(4) Adjust A2R39 (fig. 1) for a 0.01 V indication on TI meter (R).

(5) Adjust calibrator frequency to 3 MHz and output amplitude for 0.0% error display reading.

(6) Adjust A2C21 (fig. 1) for a 0.01 V indication on TI meter (R).

(7) Repeat (3) through (6) above as necessary to correct for any interaction between adjustments.

(8) Set **METER RANGE** switch to **.3 VOLTS**.

(9) Adjust calibrator frequency to 1 kHz and amplitude control for a 0.3 V indication on TI meter. Set the reference level on calibrator by pressing the **NEW REF** key.

(10) Adjust calibrator frequency to 2.5 MHz and amplitude for 0.0% error display reading.

(11) Adjust S3C6 (fig. 2) for a 0.3 V indication on TI meter (R).

(12) Set **METER RANGE** switch to **3 VOLTS**.

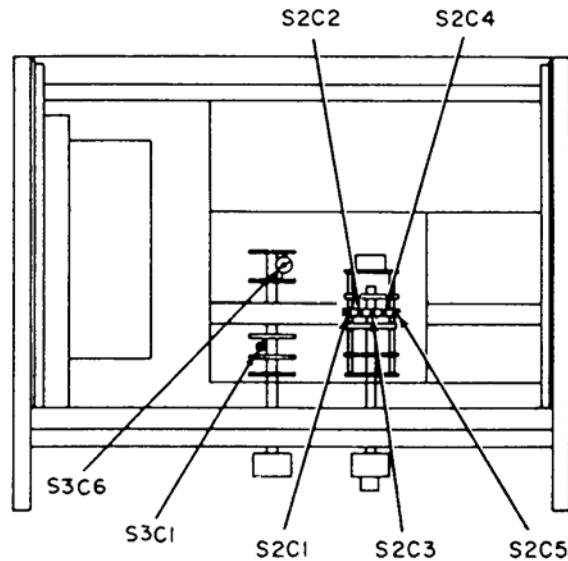

Figure 2. Distortion analyzer - bottom view.

(13) Adjust calibrator frequency to 1 kHz and amplitude control for a 3 V indication on TI meter. Set the reference level on calibrator by pressing the **NEW REF** key.

(14) Adjust calibrator frequency to 200 kHz and output amplitude for 0.0% error display reading.

(15) Adjust S3C1 (fig. 2) for a 3 V indication on TI meter (R).

10. High Pass Filter (Hewlett-Packard, Models 333A and 334A)

a. Performance Check

- (1) Connect calibrator **OUTPUT** to **TI INPUT**.
- (2) Position TI switches as listed in (a) through (c) below:
 - (a) **METER RANGE** to **.3 VOLTS**.
 - (b) **FUNCTION** to **SET LEVEL**.
 - (c) **HIGH PASS FILTER** to **IN**.
- (3) Set calibrator to **VOLT** operation and adjust frequency to 5 kHz and amplitude for a 0.3 V indication on TI meter.
- (4) Adjust TI **SENSITIVITY** controls for meter indication of 0 dB.
- (5) Adjust calibrator frequency to 1 kHz, and verify TI meter indicates within 0.5 dB of 0 dB setting.
- (6) Adjust calibrator frequency to 60 Hz, and verify TI meter indicates at least 40 dB below the 0 dB setting.

b. Adjustments. No adjustments can be made.

11. Low Pass Filter (Hewlett-Packard, Models 334A Option 002)

a. Performance Check

- (1) Connect calibrator **OUTPUT** to **TI INPUT**.
- (2) Position TI switches as listed in (a) through (c) below:
 - (a) **METER RANGE** to **.3 VOLTS**.
 - (b) **FUNCTION** to **SET LEVEL**.
 - (c) **LOW PASS FILTER** to **IN**.
- (3) Adjust calibrator frequency to 20 kHz and amplitude for a 0.3 V indication on TI meter. Set the reference level on calibrator by pressing the **NEW REF** key.
- (4) Adjust TI **SENSITIVITY** controls for a TI meter indication of 0 dB.
- (5) While maintaining 0.0% calibrator error display reading, adjust calibrator frequency until TI meter indicates -3 dB.
- (6) Verify calibrator frequency is between 27 and 33 kHz.
- (7) Adjust calibrator frequency to 60 kHz and amplitude for 0.0% calibrator error display reading. Adjust **METER RANGE** switch for an on-scale indication. TI meter indication will be less than -20 dB.

b. Adjustments. No adjustments can be made.

12. Voltmeter Residual Noise

a. Performance Check

- (1) Connect shorting bar between chassis ground and circuit ground on **INPUT** terminals.
- (2) Connect voltage divider to **TI INPUT** terminals.
- (3) Position TI switches as listed in (a) through (c) below:
 - (a) **FUNCTION** to **VOLTMETER**.
 - (b) **METER RANGE** to **.0003 VOLTS**.
 - (c) **HIGH PASS FILTER** to **OUT**.
- (4) TI meter will indicate 25 μ V or less.

b. Adjustments. No adjustments can be made.

13. Set Level Sensitivity

a. Performance Check

- (1) Connect calibrator **OUTPUT** to **TI INPUT**.
- (2) Position TI controls as listed in (a) through (c) below:
 - (a) **METER RANGE** switch to **.01 VOLTS**.
 - (b) **SENSITIVITY** switch to **MAX**.
 - (c) **SENSITIVITY VERNIER** control fully cw.

NOTE

Ensure **SENSITIVITY VERNIER** control remains fully cw throughout paragraph 13.

- (3) Adjust calibrator frequency to 400 Hz and amplitude for a 0.01 V indication on TI meter.
- (4) Set **FUNCTION** switch to **SET LEVEL**. TI meter will indicate at least 0.01 V.

NOTE

SENSITIVITY switch position will be referred to as follows: position 6 (MAX), ccw through position 1 (MIN).

- (5) Set **SENSITIVITY** switch ccw one position (to position 5).
- (6) Adjust calibrator frequency to 400 Hz and amplitude for TI meter indication of 0.94 on 0 to 1 scale. Set the reference level on calibrator by pressing the **NEW REF** key.
- (7) Adjust calibrator frequency to 100 kHz and output amplitude for 0.0% error display reading. If TI meter does not indicate between 0.92 and 0.96 on the 0 to 1 scale, perform adjustments listed in table 4.
- (8) Repeat (6) and (7) above for **SENSITIVITY** switch positions in table 4, increasing calibrator output for each respective decrease in **SENSITIVITY** position. If TI meter does not indicate between 0.92 and 0.96 on 0 to 1 scale, perform adjustments listed in table 4.

Table 4. Test Instrument Sensitivity Switch Adjustments

Sensitivity switch positions	Adjustments (fig. 2)	Test instrument meter indications
5	S2C5 (R)	0.94
4	S2C4 (R)	0.94
3	S2C3 (R)	0.94
2	S2C2 (R)	0.94
1	S2C1 (R)	0.94

b. Adjustments. No further adjustments can be made.

14. Frequency Dial Accuracy

a. Performance Check

- (1) Connect calibrator **OUTPUT** to TI **INPUT**.
- (2) Position TI controls as listed in (a) through (f) below:
 - (a) **SENSITIVITY** switch to position 5.
 - (b) **METER RANGE** switch to **.3 VOLTS**.
 - (c) **FREQUENCY RANGE** switch to **X1K**.
 - (d) **FREQUENCY** dial to **5**.
 - (e) **BALANCE** controls to midrange.

NOTE

It may be necessary to reinstall the shorting bar between TI and chassis ground terminals below 1 kHz.

- (f) **MODE** switch to **MANUAL** (Hewlett-Packard Models 333A and 334A).
- (3) Adjust calibrator frequency for 5 kHz and amplitude for an indication of 3 on TI meter 0 to 3 scale.
- (4) Set **FUNCTION** switch to **DISTORTION**.
- (5) Adjust **BALANCE** controls and calibrator frequency for a null indication on TI meter (**METER RANGE** switch may be reduced to obtain best null indication). If calibrator frequency does not indicate between 4.75 and 5.25 kHz, perform **b** below.
- (6) Set **METER RANGE** switch to **.3 VOLTS** and **FUNCTION** switch to **SET LEVEL**.
- (7) Repeat (2) through (6) above, using frequencies, control settings, and indications listed in table 5.

Table 5. Frequency Dial Accuracy

Nominal frequency	Test instrument		Calibrator frequency indications	
	FREQUENCY RANGE switch settings	FREQUENCY dial settings	Min	Max
	20 kHz	X1K	20	19.0 kHz
60 kHz	X1K	60	57.0 kHz	63.0 kHz
50 kHz	X10K	5	47.5 kHz	52.5 kHz
200 kHz	X10K	20	190 kHz	210 kHz
600 kHz	X10K	60	540 kHz	660 kHz
6 kHz	X100	60	5700 Hz	6300 Hz
2 kHz	X100	20	1900 Hz	2100 Hz
500 Hz	X100	5	475 Hz	525 Hz
50 Hz	X10	5	47.5 Hz	52.5 Hz
200 Hz	X10	20	190 Hz	210 Hz
600 Hz	X10	60	570 Hz	630 Hz
60 Hz	X1	60	57 Hz	63 Hz
20 Hz	X1	20	19 Hz	21 Hz

b. Adjustments

- (1) Position switches as listed in (a) through (c) below:
 - (a) **METER RANGE** to **.3 VOLTS**.
 - (b) **FUNCTION** to **SET LEVEL**.
 - (c) **FREQUENCY RANGE** to **X1K**.
- (2) Adjust calibrator frequency for 5 kHz.
- (3) Set **FUNCTION** switch to **DISTORTION**.
- (4) Adjust **FREQUENCY** dial for a null indication on TI meter. (Set **METER RANGE** switch as necessary for sharp null.)

(5) Slip **FREQUENCY** dial on shaft (remove knob for access to dial locking screws) until dial indication of 5 is aligned with marker (R).

(6) Set **METER RANGE** switch to **.3 VOLTS** and **FUNCTION** switch to **SET LEVEL**.

(7) Adjust calibrator frequency for 60 kHz and amplitude for an indication of 3 on TI meter 0 to 3 scale.

(8) Adjust **FREQUENCY** dial to **60**.

(9) Set **FUNCTION** switch to **DISTORTION**.

(10) Fine tune **FREQUENCY** dial for a null indication on TI meter. Record frequency dial setting.

(11) Adjust **FREQUENCY** dial to **60**.

NOTE

Because of interaction when removing protective cover, repeat technique of (10) above and compare frequency dial settings.

(12) Adjust C3 (fig. 1) for a null indication on TI meter (R).

15. Second Harmonic Rejection

a. Performance Check

(1) Connect calibrator **OUTPUT** to **TI INPUT**.

(2) Position TI controls as listed in (a) through (e) below:

(a) **FUNCTION** switch to **SET LEVEL**.

(b) **METER RANGE** switch to **SET LEVEL**.

(c) **FREQUENCY RANGE** switch to **X10K**.

(d) **FREQUENCY** dial to **50**.

(e) **SENSITIVITY** switch to **MAX**.

(3) Adjust calibrator frequency to 500 kHz and amplitude for 0 dB on TI meter.

(4) Set **FUNCTION** switch to **DISTORTION**.

(5) Adjust **FREQUENCY** dial and **BALANCE** controls for null indication on TI meter. (Set **METER RANGE** switch as necessary for sharp null.)

(6) Set **METER RANGE** switch to **0 dB** and **FUNCTION** switch to **SET LEVEL**.

(7) Adjust calibrator frequency to second harmonic of calibrator frequency used in (3) above. Adjust calibrator amplitude controls for 0 dB on TI meter.

(8) Set **FUNCTION** switch to **DISTORTION**. TI meter will indicate between -3 and 0 on dB scale.

(9) Repeat (2) through (8) above, using frequencies, control settings, and indications listed in table 6.

Table 6. Second Harmonic Rejection

Test instrument		Calibrator frequencies	Test instrument meter indications at second harmonic (dB)	
FREQUENCY RANGE switch settings	FREQUENCY dial settings		Min	Max
X10K	20	200 kHz	-2.0	0
X10K	5	50 kHz	-1.0	0
X1K	5	5 kHz	-0.6	+0.6
X1K	15	15 kHz	-0.6	+0.6
X100	20	2 kHz	-0.6	+0.6
X100	5	500 Hz	-0.6	+0.6
X10	5	50 Hz	-0.6	+0.6
X10	20	200 Hz	-0.6	+0.6
X1	15	15 Hz	0	1.0

b. **Adjustments.** No adjustments can be made.

16. Automatic Null (Hewlett-Packard, Models 333A and 334A)

a. Performance Check

- (1) Connect calibrator **OUTPUT** to **TI INPUT**.
- (2) Position **TI** controls as listed in (a) through (g) below:
 - (a) **FUNCTION** switch to **VOLTMETER**.
 - (b) **METER RANGE** switch to **1 VOLT**.
 - (c) **MODE** selector switch to **MANUAL**.
 - (d) **FREQUENCY RANGE** switch to **X100**.
 - (e) **FREQUENCY** dial to **50**.
 - (f) **SENSITIVITY** switch to **MAX**.
 - (g) **SENSITIVITY VERNIER** control to **MIN**.
- (3) Adjust calibrator for 5 kHz and adjust level for a 1 V indication on **TI** meter.
- (4) Set **FUNCTION** and **METER RANGE** switches to **SET LEVEL**.
- (5) Adjust **SENSITIVITY** and **VERNIER** controls for a +2 dB indication on **TI** meter.
- (6) Set **FUNCTION** switch to **DISTORTION**.
- (7) Adjust **FREQUENCY** dial and **BALANCE** controls for a null indication on **TI** meter.
- (8) Reduce **METER RANGE** switch as necessary to maintain an on-scale reading. Record **TI** meter reading.
- (9) Set **METER RANGE** switch to **100% (SET LEVEL)**.
- (10) Adjust **FREQUENCY** dial and **BALANCE** controls for a null indication on **TI** meter. When **TI** indication is less than 3% on 0 to 3% (**SET LEVEL**) scale, set **MODE** switch to **AUTOMATIC**.

(11) Reduce **METER RANGE** switch as necessary to maintain an on-scale reading. Record TI meter reading.

(12) Compare readings recorded in (8) and (11) above. If difference exceeds value recorded in (8) above by more than 1.5 dB, perform **b** below.

(13) Set **METER RANGE** switch to **100% (SET LEVEL)** and **MODE** switch to **MANUAL**.

(14) Repeat technique of (2) through (13) above for TI frequency dial settings and indications listed in table 7. If difference between **MANUAL** and **AUTOMATIC** null exceeds limits specified, perform **b** below.

Table 7. Automatic Null

Calibrator frequencies (kHz)	Test instrument		Difference between MANUAL null and AUTOMATIC null (dB)
	FREQUENCY RANGE switch settings	FREQUENCY dial settings	
50	X1K	50	+1.5
100	X10K	10	+1.5
250	X10K	25	+1.5
600	X10K	60	+1.5
.035	X1	35	+3.0
.400	X10	40	+1.5

b. Adjustments

(1) Repeat **a** (2) through (7) above.

(2) Set **MODE** selector switch to **AUTOMATIC**.

(3) Set **METER RANGE** switch to **.0003 VOLTS**.

(4) Rotate A3R30 (fig. 1) ccw and then cw for best null indication on TI meter.

Record TI meter indication.

NOTE

When adjusting A3R30, turn control a small increment and allow TI meter indication to stabilize before obtaining TI indication.

(5) Adjust A3R30 cw for 1 minor division (on TI meter 0 to 1 scale) above indication recorded in (4) above (R).

(6) Repeat **a** above.

17. Fundamental Frequency Rejection

a. Performance Check

(1) Connect equipment as shown in figure 3.

(2) Position TI controls as listed in (a) through (g) below:

(a) **FUNCTION** switch to **VOLTMETER**.

- (b) **METER RANGE** switch to **1 VOLT**.
- (c) **MODE** selector switch to **MANUAL**.
- (d) **FREQUENCY RANGE** switch to **X10**.
- (e) **FREQUENCY** dial to **50**.
- (f) **SENSITIVITY** switch to **MAX**.
- (g) **SENSITIVITY VERNIER** control to **MIN**.

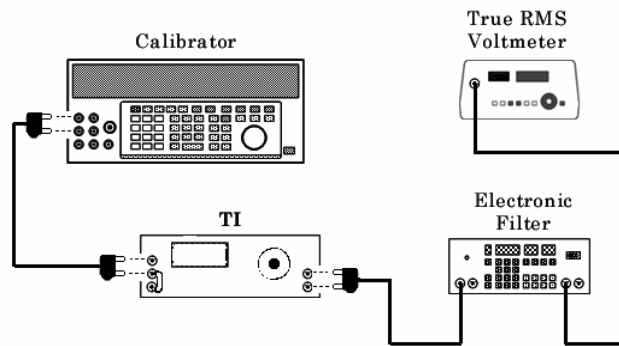

Figure 3. Fundamental frequency rejection - equipment setup.

- (3) Adjust electronic filter for a 500 Hz bandpass frequency.
- (4) Adjust calibrator frequency to 500 Hz and output level for a 1 V indication on TI meter.
- (5) Set **FUNCTION** and **METER RANGE** switches to **SET LEVEL**.
- (6) Adjust **SENSITIVITY** and **VERNIER** controls for a **0 dB** indication on TI meter. Record true rms voltmeter dB indication.
- (7) Set **FUNCTION** switch to **DISTORTION**.
- (8) Adjust **FREQUENCY** dial and **BALANCE** controls for a null indication on TI meter. When TI indication is less than 10% on the **0 to 10% (SET LEVEL)** scale, set **MODE** switch to **AUTOMATIC**.
- (9) Reduce **METER RANGE** switch as necessary to maintain an on-scale reading.

NOTE

Each decrease in the **METER RANGE** switch represents 10 dB of fundamental rejection; therefore, the total fundamental rejection is the sum of the TI **METER RANGE** setting and the true rms voltmeter amplitude reading.

- (10) Add dB readings of **METER RANGE** switch and true rms voltmeter. Total dB change will be greater than 80 dB below indication recorded in (6) above.
- (11) Set **METER RANGE** switch to **0 dB**, **MODE** switch to **MANUAL** and **FUNCTION** switch to **SET LEVEL**.
- (12) Repeat (2) through (10) above, using TI control settings and frequencies listed in table 8.

Table 8. Fundamental Frequency Rejection

Test Instrument		Electronic filter cut-off frequencies (kHz)	Calibrator frequencies (kHz)
FREQUENCY RANGE switch settings	FREQUENCY dial settings		
X100	50	5	5
X1K	50	50	50
X10K	10	95	95 ¹

¹Total change will be at least 70 dB below indication recorded in (4) above.

b. **Adjustments.** No adjustments can be made.

18. **Fundamental Frequency Rejection (Alternate Method)**

a. **Performance Check**

- (1) Connect equipment as shown in figure 4.
- (2) Repeat 17 a (2) and (4) through (5) above.
- (3) Adjust **SENSITIVITY** and **VERNIER** controls for a 0 dB indication on TI meter. Record spectrum analyzer 500 Hz signal amplitude (as reference).
- (4) Repeat 17 a (7) and (8) above.
- (5) Add dB readings of **METER RANGE** switch and spectrum analyzer signal amplitude. Total dB change will be greater than 80 dB below indication recorded in (3) above.

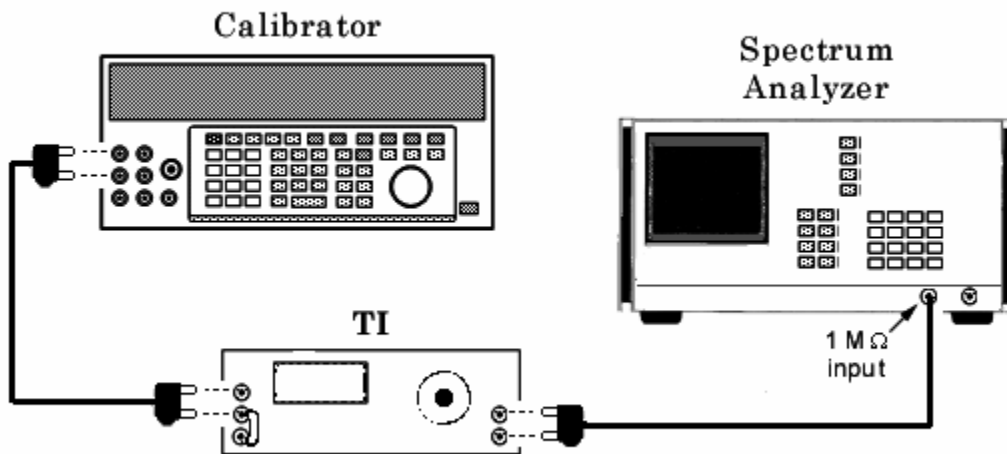

Figure 4. Fundamental frequency rejection (alternate method) - equipment setup.

TB 9-6625-1098-35

(6) Set **METER RANGE** switch to **0 dB**, **MODE** switch to **MANUAL**, and **FUNCTION** switch to **SET LEVEL**.

(7) Repeat (2) through (5) above, using TI control settings and frequencies listed in table 9.

Table 9. Fundamental Frequency Rejection (Alternate Method)

Test instrument		Spectrum analyzer center frequencies (kHz)	Calibrator frequencies (kHz)
FREQUENCY RANGE switch settings	FREQUENCY dial settings		
X100	50	5	5
X1K	50	50	50
X10K	10	95	95 ¹

¹Total change will be at least 70 dB below indication recorded in (3) above.

b. Adjustments. No adjustments can be made.

19. Power Supply

a. Performance Check

NOTE

Do not perform power supply check if all other parameters are within tolerance.

(1) Connect multimeter between TI chassis ground and pin 5 on circuit board A2 (pin 2 on circuit board A5) (fig. 1), using probe (B6). If multimeter does not indicate between -24.5 and -25.5 V dc, perform **b** (1) below.

(2) Connect multimeter between TI chassis ground and pin 13 of circuit board A2 (pin 4 on circuit board A5) (fig. 1). Multimeter will indicate between +24.0 and +26.0 V dc.

(3) Connect multimeter between A2TP2 (fig. 1) and chassis ground. If multimeter does not indicate between +7.7 and +8.7 V dc, perform **b** (2) below.

(4) Connect multimeter between A3TP1 (fig. 1) and chassis ground. If multimeter does not indicate between +2.45 and +2.85 V dc, perform **b** (3) below.

(5) Connect multimeter between A3TP2 (fig. 1) and chassis ground. If multimeter does not indicate between -19.9 and -20.5 V dc, perform **b** (4) below.

(6) Connect multimeter between A2TPI (fig. 1) and chassis ground. If multimeter does not indicate between -11.2 and -11.4 V dc, perform **b** (5) below.

b. Adjustments

(1) Adjust A1R13 (fig 1) for a -25 V dc indication on multimeter (R).

(2) Adjust A2R20 (fig. 1) for a +8.2 V dc indication on multimeter (R).

(3) Adjust A3R4 (fig. 1) for a +2.65 V dc indication on multimeter (R).

(4) Adjust A3R16 (fig. 1) for a -20.2 V dc indication on multimeter (R).

(5) Adjust A2R3 (fig. 1) for a -11.3 V dc indication on multimeter (R)

20. Final Procedure

- a.** Deenergize and disconnect all equipment.
- b.** Annotate and affix DA label/form in accordance with TB 750-25.

By Order of the Secretary of the Army:

Official:



JOEL B. HUDSON

*Administrative Assistant to the
Secretary of the Army*

0403502

PETER J. SCHOOMAKER

*General, United States Army
Chief of Staff*

Distribution:

To be distributed in accordance with the initial distribution number (IDN) 342118, requirements for calibration procedure TB 9-6625-1098-35.

Instructions for Submitting an Electronic 2028

The following format must be used if submitting an electronic 2028. The subject line must be exactly the same and all fields must be included; however, only the following fields are mandatory: 1, 3, 4, 5, 6, 7, 8, 9, 10, 13, 15, 16, 17, and 27.

From: "Whomever" whomever@redstone.army.mil
To: <2028@redstone.army.mil

Subject: DA Form 2028

1. **From:** Joe Smith
2. **Unit:** home
3. **Address:** 4300 Park
4. **City:** Hometown
5. **St:** MO
6. **Zip:** 77777
7. **Date Sent:** 19-OCT -93
8. **Pub no:** 55-2840-229-23
9. **Pub Title:** TM
10. **Publication Date:** 04-JUL-85
11. **Change Number:** 7
12. **Submitter Rank:** MSG
13. **Submitter FName:** Joe
14. **Submitter MName:** T
15. **Submitter LName:** Smith
16. **Submitter Phone:** 123-123-1234
17. **Problem:** 1
18. **Page:** 2
19. **Paragraph:** 3
20. **Line:** 4
21. **NSN:** 5
22. **Reference:** 6
23. **Figure:** 7
24. **Table:** 8
25. **Item:** 9
26. **Total:** 123
27. **Text**

This is the text for the problem below line 27.

